

SMP

SELFPRIMING MAGNETIC DRIVE
CENTRIFUGAL PUMPS PP

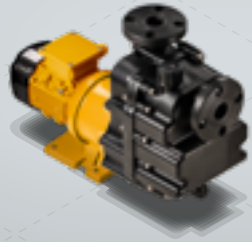

SMP

Selfpriming, magnetic drive centrifugal pumps



Housing and impeller materials: PP
Elastomers: EPDM, FKM (e.g. Viton®)
Bushing materials: Graphite carbon/ Al_2O_3

The SMP series is specially designed for self-priming operation. It is particularly suitable if the pump has to draw from a lower container and the suction line is filled with air. The SMP series features a contact- and abrasion-free magnetic drive system, so that no mechanical seal is required to seal the pump.

Advantages:

- + Suction heights up to 7 m (depending on the size)
- + Hermetically sealed and absolutely leak-free (no mechanical seal)
- + Particularly suited for toxic, environmentally harmful and corrosive media

PERFORMANCE CHART

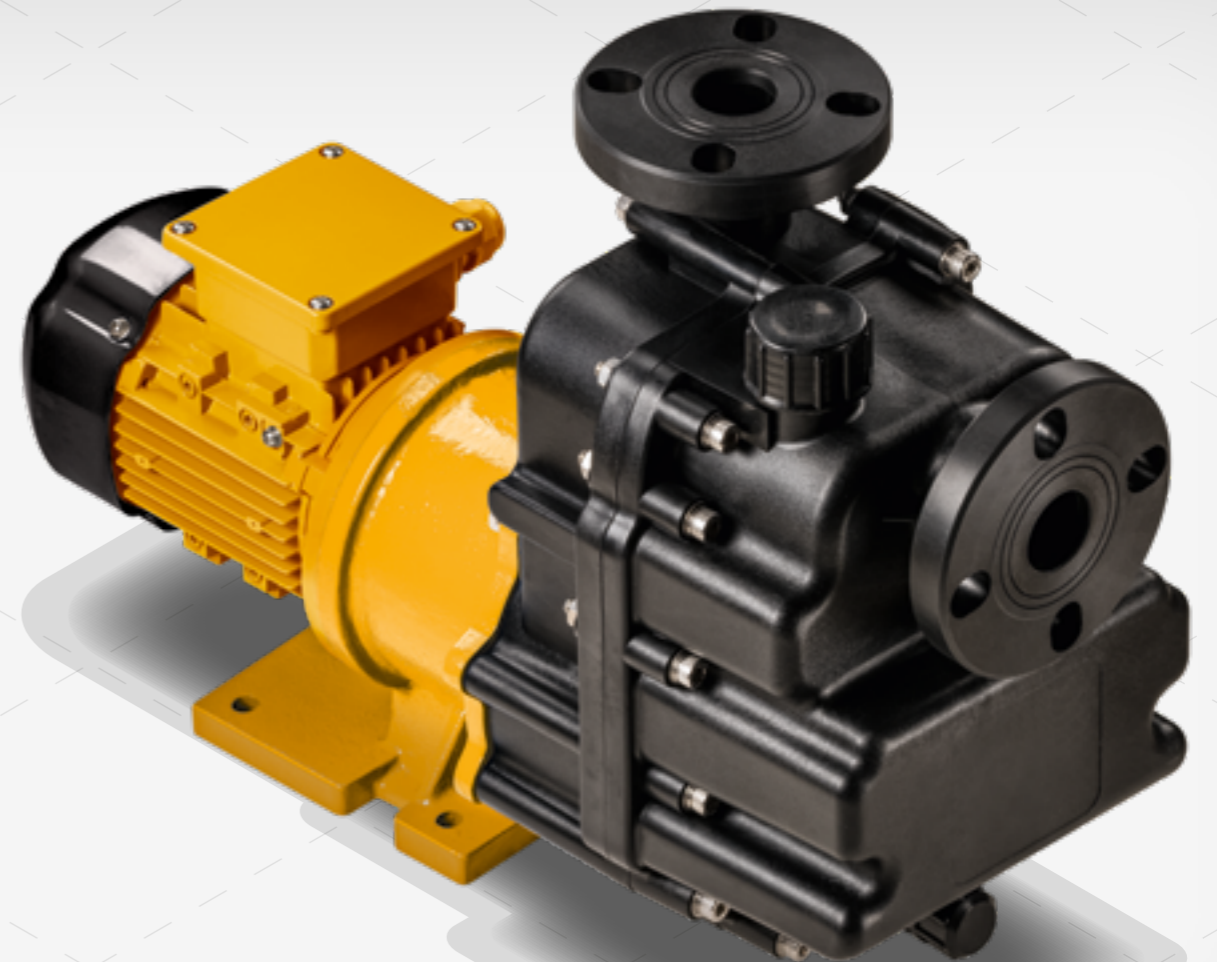
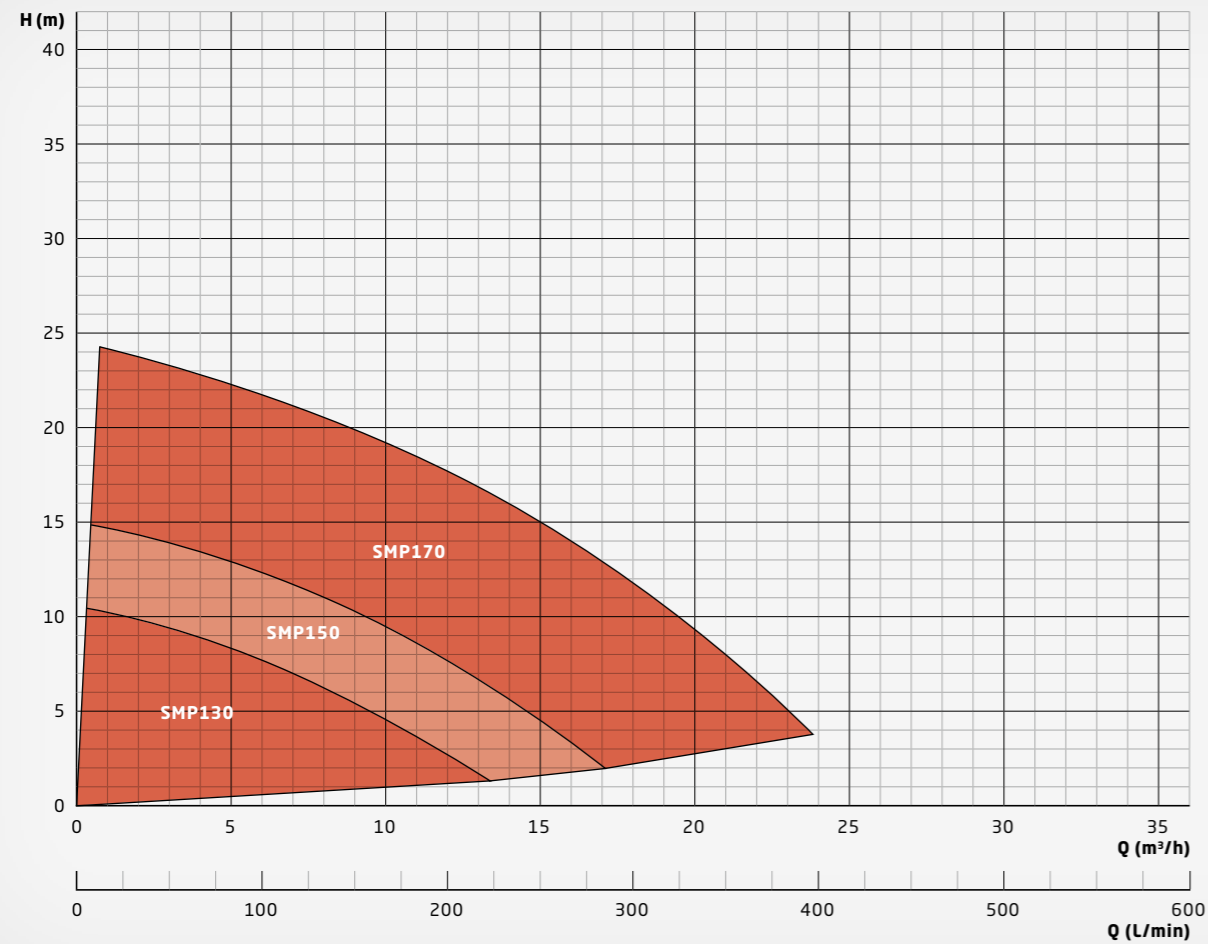

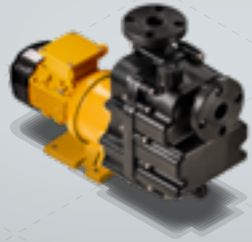

SMP

Selfpriming, magnetic drive centrifugal pumps



DESCRIPTION

Characteristics	Chemical-resistant, single-stage, magnetic drive, selfpriming centrifugal pump
Features	<ul style="list-style-type: none"> · Hermetically sealed and absolutely leak-free (no mechanical seal) · Contact-free magnetic drive system · All wet parts made of high-quality, corrosion-resistant plastics or PP · Flanges and threaded connections as standard · Universally applicable, low-noise and compact close-coupled design · Corrosion-resistant paint finish · All stainless steel screws in 1.4571 (316Ti)
Fields of application	<p>Delivery of acids, bases or other corrosive, harmful or toxic liquids in such applications where the pump is installed above the liquid level and a hermetically sealed pump is required.</p> <p>For example in the following applications:</p> <ul style="list-style-type: none"> · Plating and surface coating · Semiconductor technology and solar cell production · PCB and electronics manufacturing · Wastewater and fresh water treatment · Laboratory equipment and medical technology, · Emission controls and gas scrubbers · Battery production and energy storage · High-purity applications, demineralized water, ultrapure water

TYPES

Characteristics	<ul style="list-style-type: none"> · Pump housing / wet end: PP · Elastomers: FKM, EPDM · Material of slide bearings: Graphite carbon / Al₂O₃
Standard motors (available from stock)	<ul style="list-style-type: none"> · Three-phase motors: D230 / Y400 V-3ph @ 50 Hz, D265 / Y460 V-3ph @ 60 Hz, IP 55, Ins.-Cl. F, also with PTC · All motors from 0.75 kW have energy efficiency class IE3 · Single-phase motors (up to 1.1 kW: 230 V-1ph, 50 / 60 Hz, IP 55, Isol.-Kl. F) · ATEX-certified motors (temperature rating T3)
Special motors (available on request, for example)	<ul style="list-style-type: none"> · Special voltages and frequencies · ATEX-certified motors (temperature rating T4) · Three-phase motors with integrated drive / frequency converter · Four-pole motors with 1450 rpm @ 50 Hz / 1650 rpm @ 60 Hz · UL- and CSA-certified motors · Special types of protection, e.g. IP 65 · Special insulation classes, e.g. tropical insulation · Multi-voltage, e.g. D220-290 / Y380-500 V, 50 Hz; D220-332 / Y380-575 V, 60 Hz · Direct-current motors (DC or BLDC)
Operating conditions	<ul style="list-style-type: none"> · Max. flow rate: up to 23 m³/h · Max. delivery head: up to 24 m · Liquid temperature: 0 to 60°C (PP) · Ambient temperature: -10 to 40°C, higher temperatures on request · Pumps can be adapted to high-density liquids (up to 2.0)

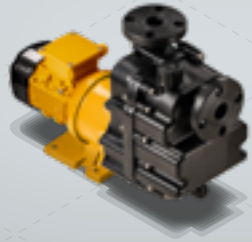

SMP

Selfpriming, magnetic drive centrifugal pumps



CHARACTERISTIC LINE SMP 130

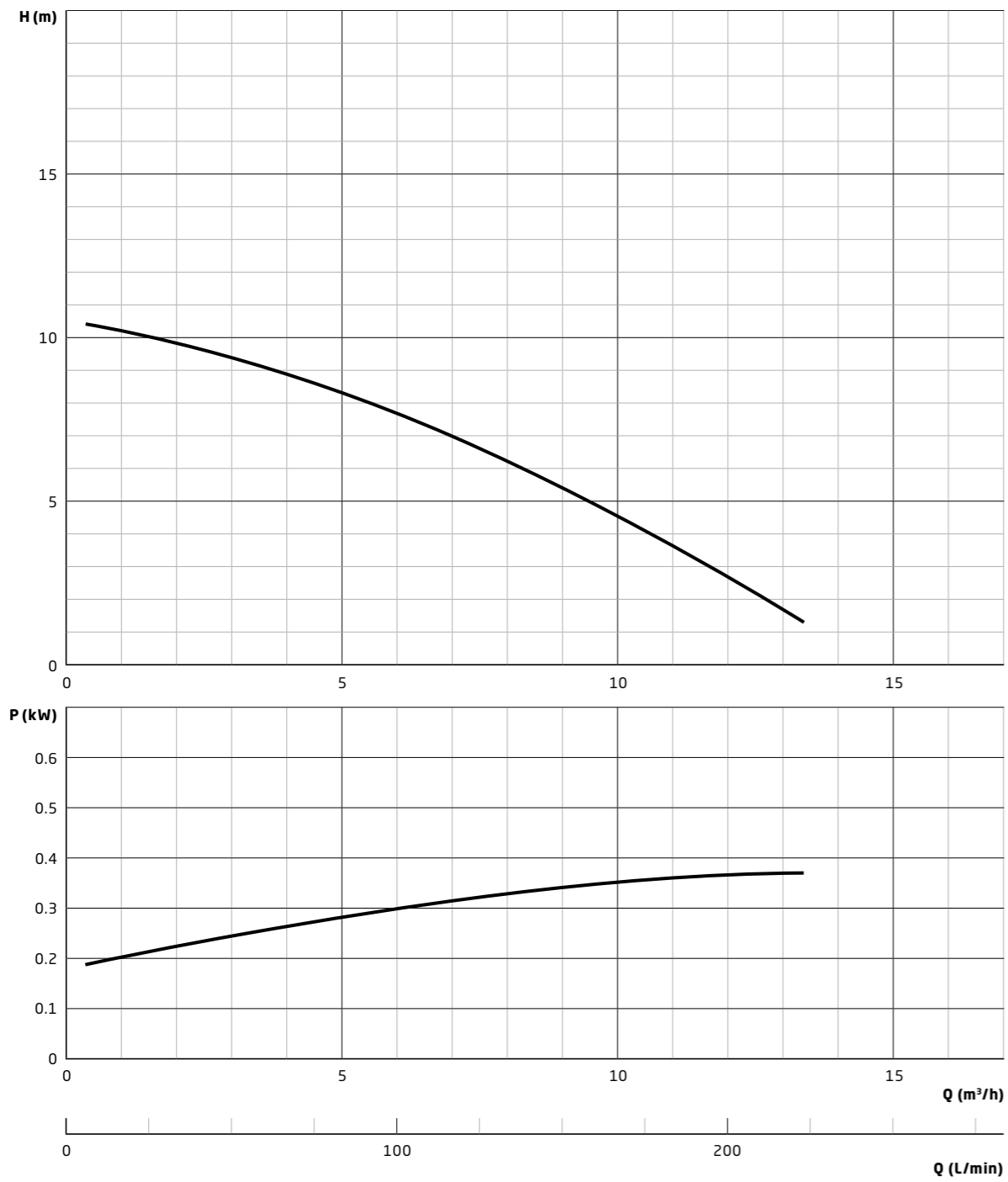

CHARACTERISTIC LINE SMP 150

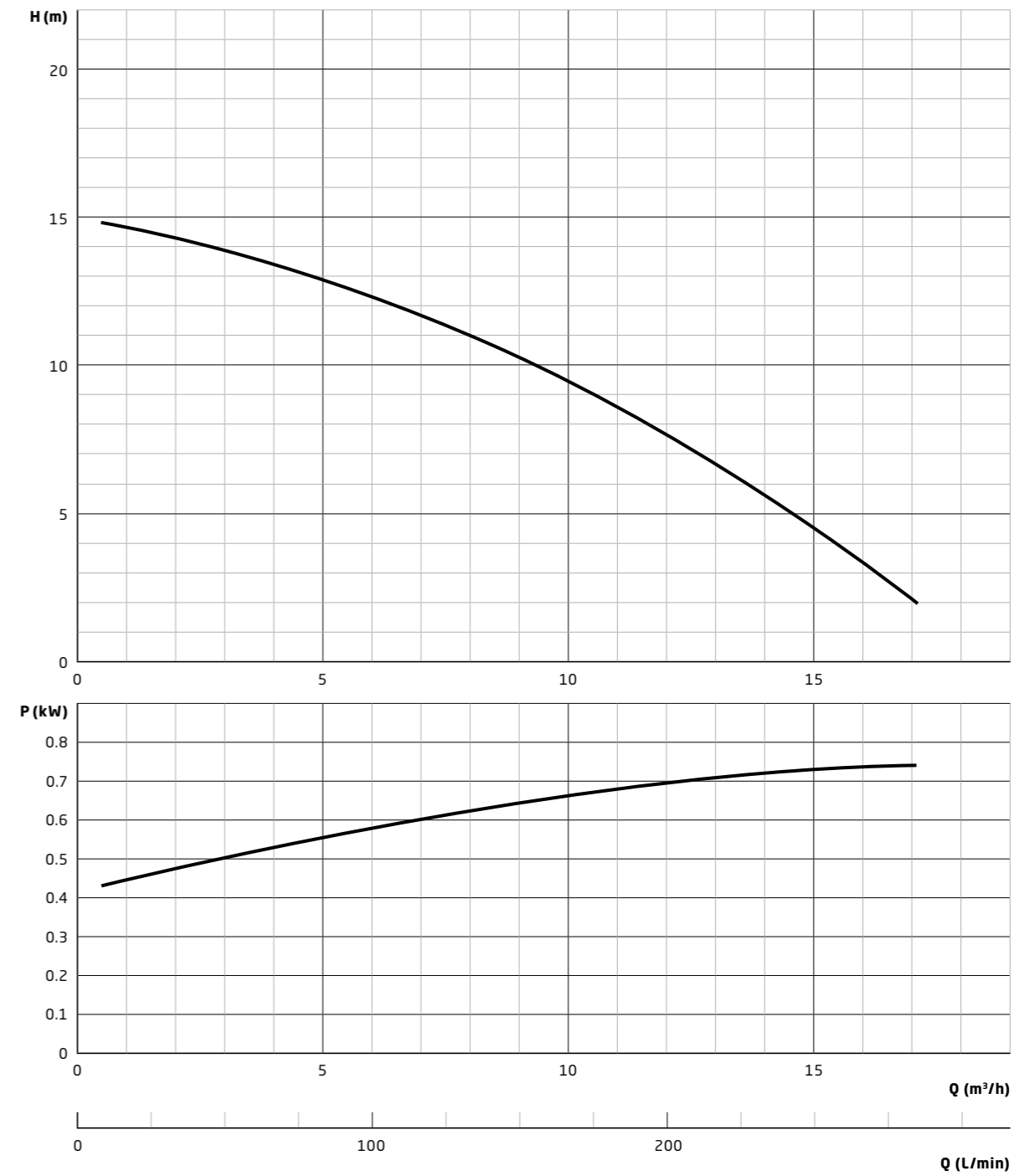

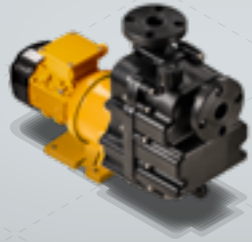

SMP

Selfpriming, magnetic drive centrifugal pumps



CHARACTERISTIC LINE SMP 170

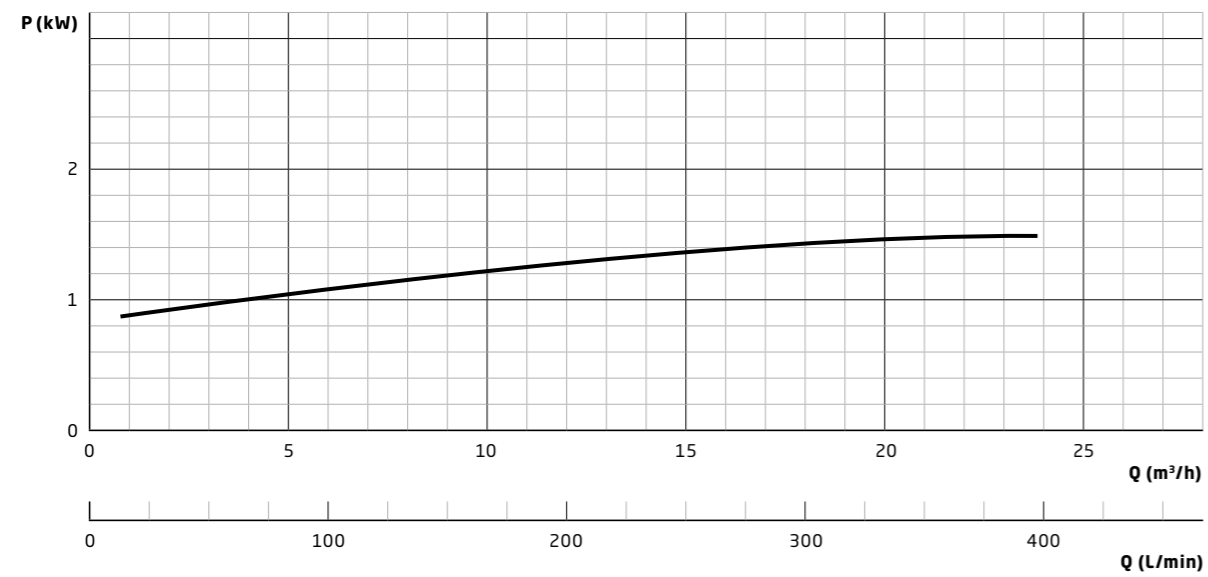
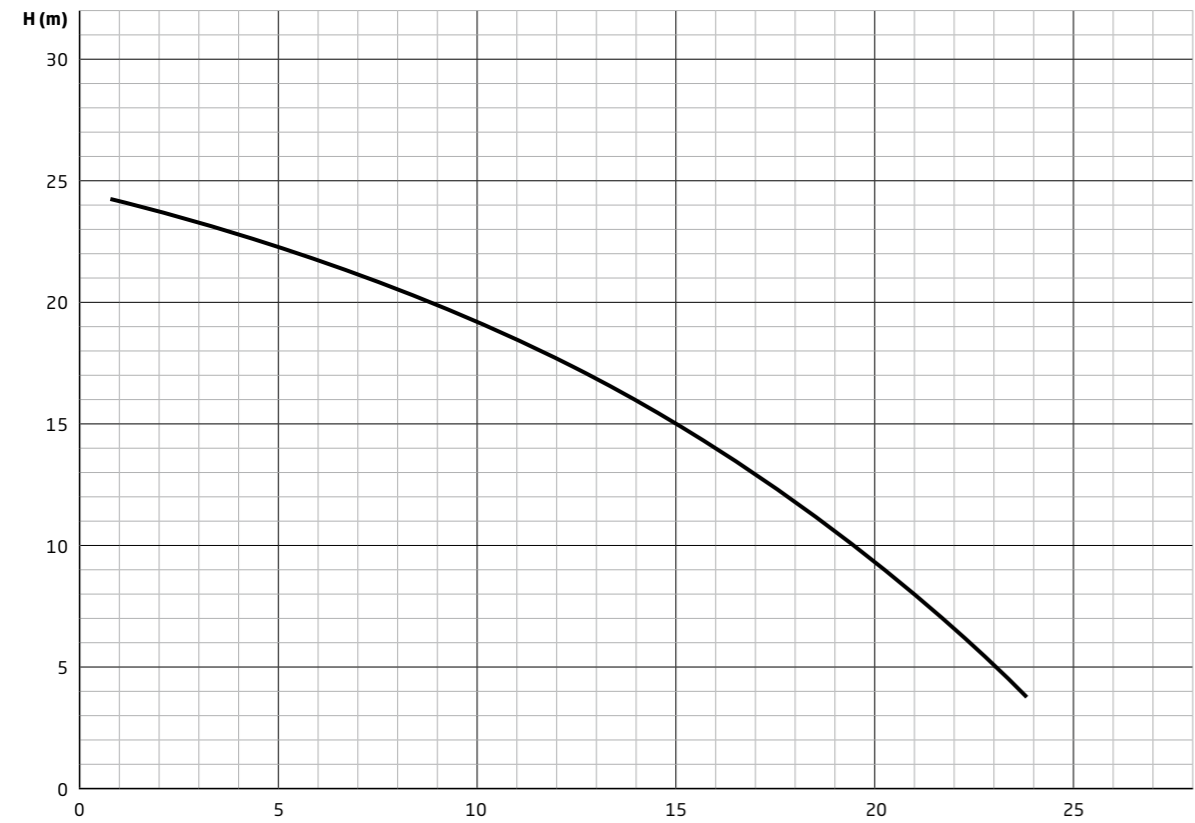

SUCTION PERFORMANCE SMP 130 / SMP 150 / SMP 170

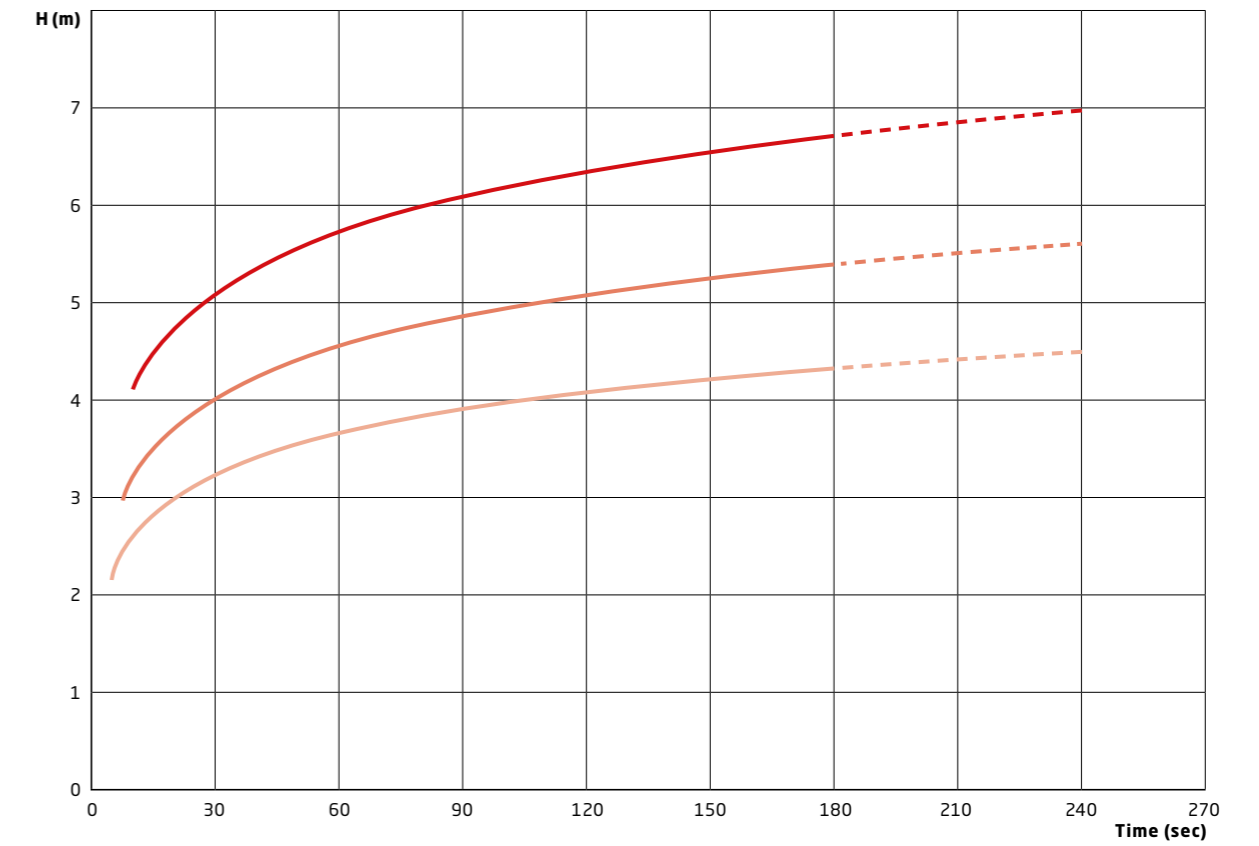

Remark: at water 20°C, density 1,0kg/m³, suction pipe d=DN

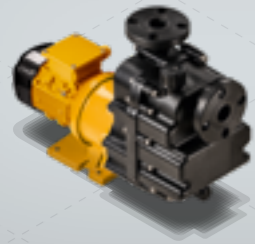

SMP

Selfpriming, magnetic drive centrifugal pumps



DIMENSIONS

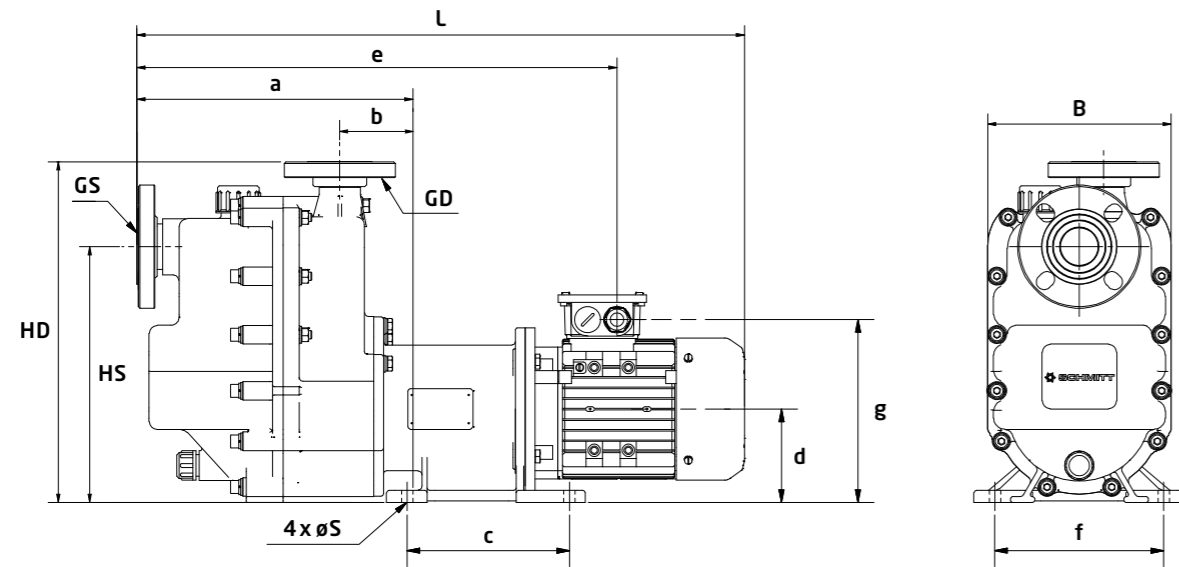

Type	GS		GD		L (mm)	B (mm)	HD (mm)	HS (mm)	øS (mm)	a (mm)	b (mm)	c (mm)	d (mm)	e (mm)	f (mm)	g (mm)
	Thread	DN	Thread	DN												
130	G1½"	40	G1½"	40	588	226	391	285	12	309	96	130	115	471	130	200
150	G1½"	40	G1½"	40	636	226	391	285	12	309	96	130	115	475	130	220
170	G2"	50	G1½"	40	749	226	420	315	12	340	90	200	115	592	208	225

FITTINGS

SCHMITT offers an extensive range of fittings to facilitate the installation of the pump into your system:

- flange adaptors
- hose connectors
- welding connectors for stainless steel pipes
- reducers
- NPT threaded adaptors
- inlet strainers for vertical pumps
- extension pipes for vertical pumps

SPARE PARTS LIST

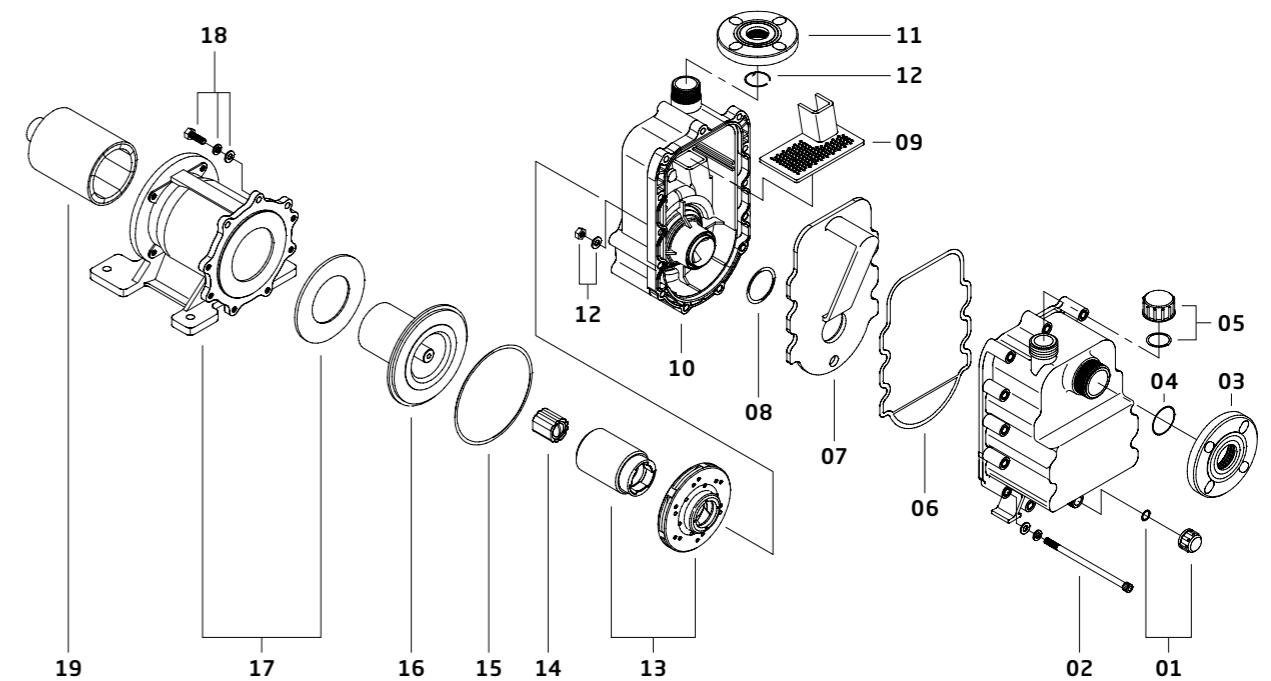

Position	Description
01	Drain cap
02	Hexagon socket screw
03	Flange
04	O-Ring
05	Filler cap + O-ring
06	Housing seal
07	Separating plate
08	O-ring
09	Filter
10	Rear casing

Position	Description
11	Flange
12	O-ring
13	impeller
14	Bushing
15	O-ring
16	Backplate
17	Flange
18	Hexagon bolt
19	Drive magnet



SCHMITT-Kreiselpumpen GmbH & Co. KG

Einsteinstraße 33

76275 Ettlingen, Germany

Fax: +49 7243 5453-22

E-mail: sales@schmitt-pumpen.de

Direct line:

Telephone: +49 7243 5453-0

www.schmitt-pumpen.de

We reserve the right to make changes to the technical information contained in this brochure without prior notice.
All data is without obligation and non-binding.

Last update: 04 / 2023